

100 90 80 70 60 50 40 30 20 10 C.R.L. 10 20 30 40 50 60 70 80 90 100

UPDATED EARTHWORK 10/18/17
VOLUME
C.Y.
EXC. EMB.

AREA
S.F.
EXC. EMB.

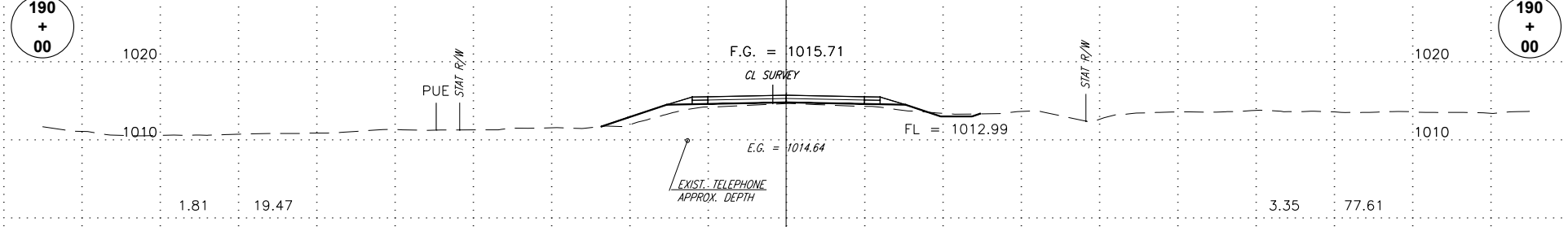
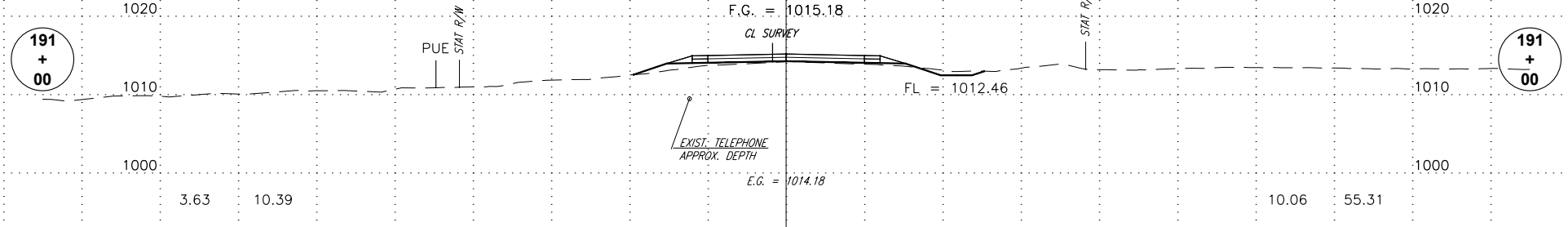
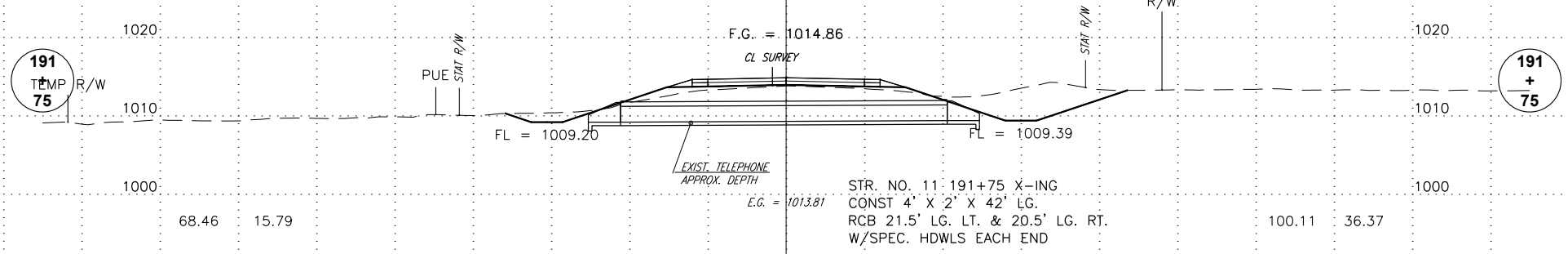
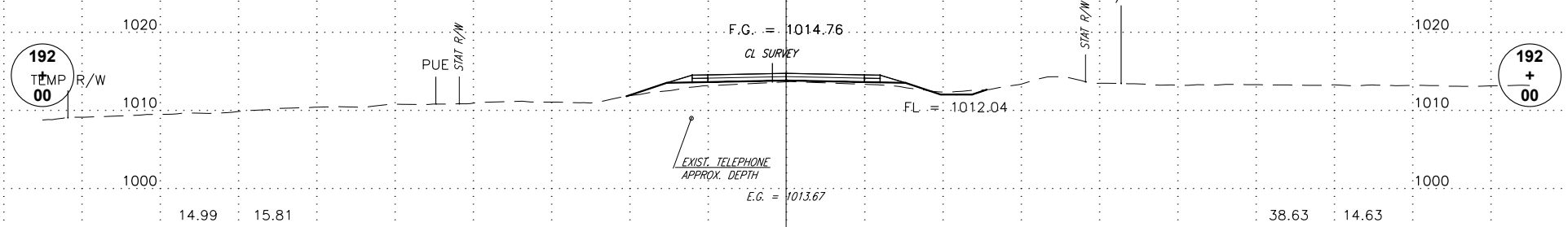
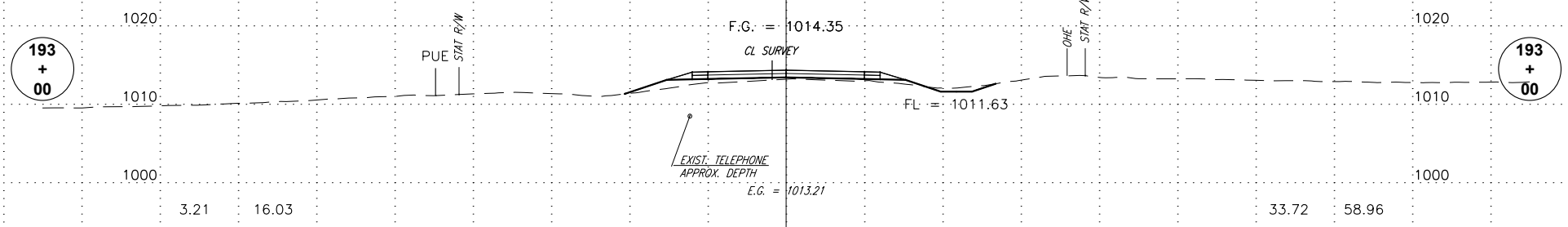
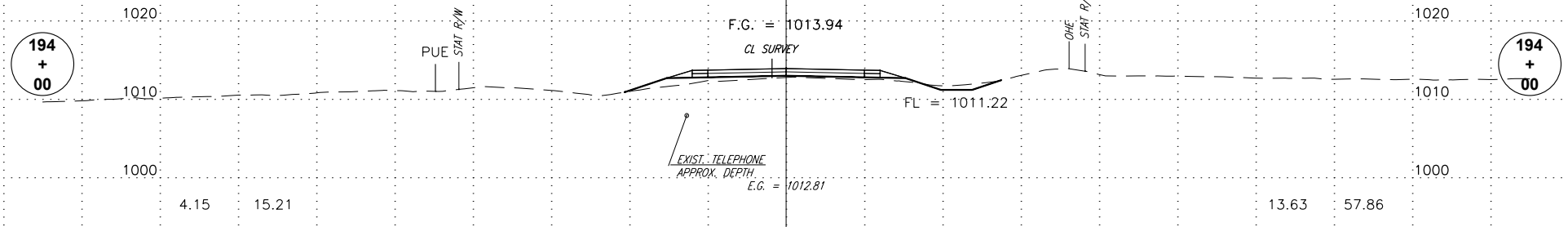

ALL UTILITY LOCATIONS AND DEPTHS ARE APPROXIMATE.



FILE: 12010.0.EW-187 P-BASEMAP.DWG
DATE: 10/18/17 STATE JOB PIECE NO. 27847(04) SHEET NO. X017

100 90 80 70 60 50 40 30 20 10 C.R.L. 10 20 30 40 50 60 70 80 90 100